



## MAL Battery Charger

### Modular Lithium-Ion Battery Charging Station

The MAL Battery Charger is a modular battery charging station for Visual Engineering SLI-50 battery packs.

The SLI-50 battery pack provides the power for the majority of Visual Engineering’s products.

The charging station’s modular configuration can be defined at the time of order to support either 2, 4 or 6 way battery charging.

This flexibility allows the battery charger to be configured to match the power requirement of the system it is to support.

Bundled with many VE products and also available individually the charger takes full advantage of the battery management circuitry in the SLI-50 battery.

The full colour OLED screen displays accurate information on the battery condition, capacity and time to charge.

The charger is powered by the supplied AC/DC mains power supply. The higher rated mains supply is required for the 4 and 6 way configurations.

#### Overview

Li-Ion Battery Charging Station

SLI-50 Battery Charging

Expandable Design

2 Way Battery Charging

4 Way Battery Charging

6 Way Battery Charging

Battery Monitoring

OLED Status Screen

Displays Charge Capacity

Displays Time To Charge

Quick Release Battery Lock

#### Battery Charger Part Numbers

<b>2 Way Charger</b>	110-0475
<b>4 Way Charger</b>	110-0478
<b>6 Way Charger</b>	110-0479

#### Power Supply Part Numbers

<b>2 Way Charger PSU</b>	110-0474
<b>4 &amp; 6 Way Charger PSU</b>	110-0477



### 6 Way Configuration



### 2 Way Dimensions

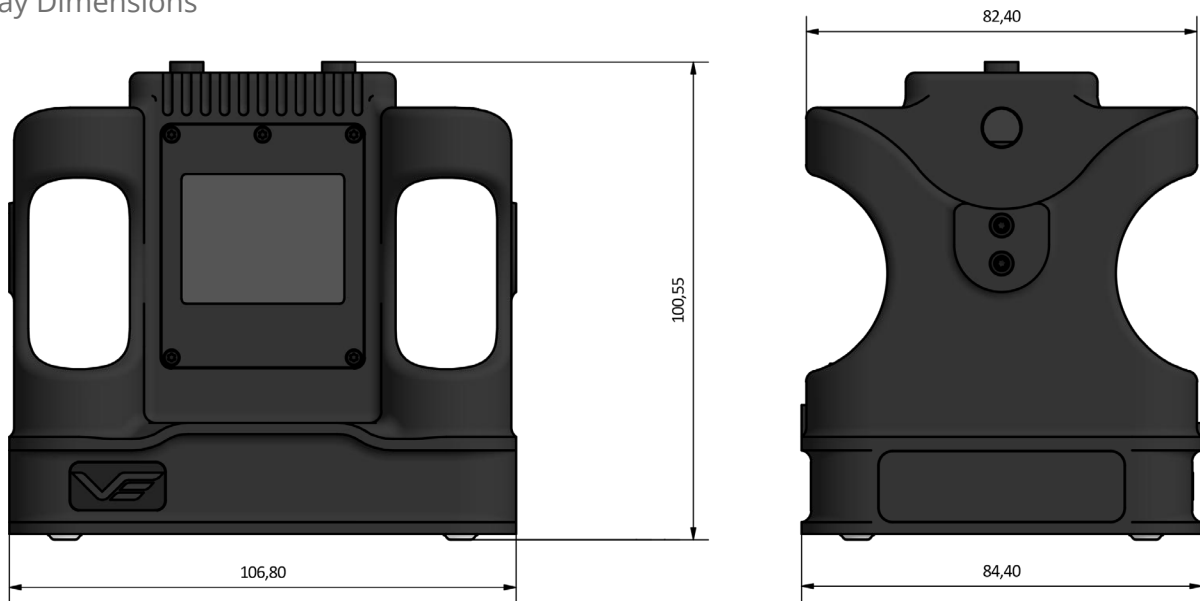

Specifications			
<b>Chemistry</b>	Lithium Ion	<b>Charge Rate</b>	2A per Channel
<b>Battery Charging</b>	2, 4 and 6 Way	<b>Operating Temperature</b>	-20 to +50°C
<b>Nominal Voltage</b>	14.8V	<b>2 Way Dimensions</b>	107 x 101 x 84mm
<b>Battery Charge Time</b>	2.5 Hours	<b>2 Way Weight</b>	300g

#### Visual Engineering Technologies LTD

Kemps Farm  
Stanway  
Colchester  
Essex  
CO3 8NB  
UK



Product specifications subject to change without notice

**Tel:** +44 (0)1206 211842  
**Web:** [www.visualengineering.co.uk](http://www.visualengineering.co.uk)  
**Email:** [sales@visualengineering.co.uk](mailto:sales@visualengineering.co.uk)