



DropCam-SDR

Rapid Deployable Mesh Camera

The DropCam-SDR is a Mesh enabled camera module which incorporates a DTC Software Defined Radio, a HD camera, a microphone, a flexible antenna pair and a battery.

The simple to use button interface allows the DropCam-SDR to be rapidly deployed.

Demand for system flexibility has led to Mesh being the first choice for transferring video. A digital Mesh radio network allows encoded video, audio and data to be shared between several nodes simultaneously.

COFDM point to point type RF transmission is also supported as a configurable option.

The video output is configurable as either HD or a standard definition windowed version of the video. SD video mode supports a solid state PTZ function by taking advantage of a 3x lossless digital zoom made possible by using the HD sensor as its source.

The DropCam-SDR also supports the option to externally connect IP cameras and HD-SDI cameras as its video source.

The transmitted video can be observed using the TM-RX Mesh Receiver partner product.

The DropCam-SDR can also be configured exclusively as a Mesh relay node. When coupled with high gain antennas it allows the connection of remote nodes that would otherwise be outside the network's RF coverage. This mode of configuration optimises battery life by switching off the internal video encoder and camera module.

Input and output triggers are also supported which allow the control of auxiliary systems. It also incorporates four LEDs which can be either white light or infrared.

This is all housed in a very rugged CNC machined waterproof enclosure.

Security of the link is ensured either through standard DES encryption or optional AES128 or AES256.

Overview

Rapid Deployable
Mesh Video Transmission
Simple Quick Setup
HD Image Sensor
Solid State PTZ for SD Video
External IP Camera Input
External HD-SDI Camera Input
Configurable as a Relay Node
White and IR LED Illumination
High Quality Microphone
Integral Rechargeable Battery
Status Screen
Ethernet Connection
Web Page Configurable
Encrypted Transmission
IP67 Rated
Rugged Build for Tactical Operations

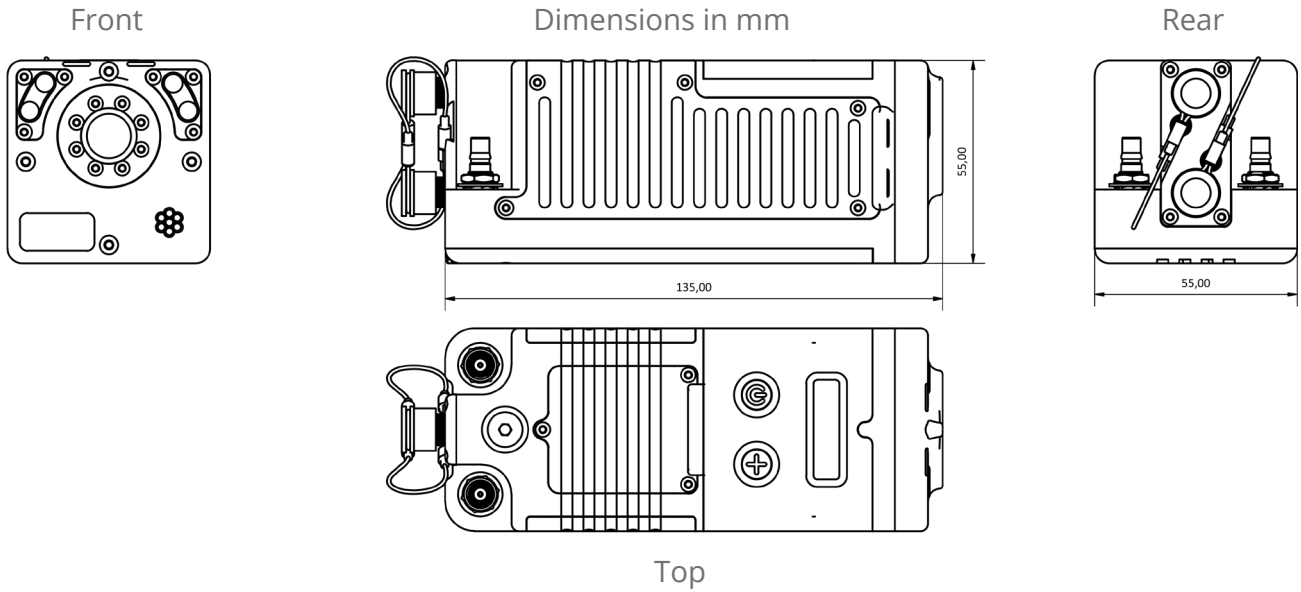

Specifications			
Camera Sensor	3.1 Megapixel, CMOS	External Camera Inputs	IP, HD-SDI
Camera Sensitivity	< 0.1 Lux	External Triggers	Input and Output
Camera SNR	> 50dB	Cable Connection	Ethernet
Horizontal FOV	120°	Configuration	Web Interface
RF Frequency	L-Band, S-Band, C-Band	LEDs	4 x White or IR
RF Type	COFDM Mesh and PtoP	Setup Interface	Button
Pan Tilt Zoom	Supported in SD Mode	Status	OLED Screen
Video Encoder Control	Relay Node Configurable	Integral Battery	Rechargeable
Video Encoding	H.264	Run Time	3 Hours
Audio	High Quality Microphone	Weight	600g
Encryption	DES, AES128, AES256	Environmental	IP67
Antennas	Flexible Dual Diversity	Dimensions	135 x 55 x 55 mm

Visual Engineering Technologies LTD

Kemps Farm
Stanway
Colchester
Essex
CO3 8NB
UK



Product specifications subject to change without notice

Tel: +44 (0)1206 211842
Web: www.visualengineering.co.uk
Email: sales@visualengineering.co.uk